

REACH IN BLAST CHILLER

WBC-110R

The WBC110 is designed to reduce the temperature of 2" thick, uncovered food from 160°F to 38°F in approximately 90 minutes and is built to ISO 9000 & 14001 standards.

Cabinet

The cabinet front, sides, door and work surface are constructed of heavy gauge polished stainless steel to maintain an attractive appearance after years of heavy use.

Doors

The door is self closing and has an easy to replace easy-to-replace magnetic balloon gasket to prevent the cold air from escaping. Door heater is standard to prevent condensation from forming on the cabinet front. The interior door liner is constructed of heavy gauge stainless steel.

Control Panel

The unique 1-2-3 microprocessor control panel initiates blast cycles in three simple steps. Model features built-in alarms and can control the chilling process with the temperature probes or a digital timer, which can be programmed with two preset chilling times for specific food products. The controller supports a la carte style blast chilling.

The cabinet automatically defrosts and reverts to a +38°F storage mode after the blast chill cycle.

HACCP Data Logger System records, stores and prints temperature data for up to 7 days in accordance with HACCP guidelines. Its built-in thermal printer provides simplified documentation and HACCP record keeping.

Model may be used with an optional NAFEM Data Protocol compliant documentation software for HACCP monitoring. Program transfers data between the kitchen and a remote Windows® compatible computer system. This program is available from the factory and many third-party suppliers.

Standard Features

- Two operational functions:
 - Blast chill processing refrigerator
 - +38°F storage refrigerator
- 1-2-3 microprocessor control panel:
 - Blast chill cycle controlled automatically by either a food probe or digital timer
 - Two (2) preset chill times: 90, 240 minutes
 - Soft chill and hard chill options
 - Three (3) food probes with digital temperature indication
 - Continuous blast feature
 - Cabinet temperature digital display
 - Food temperature digital display
 - Defrost mode indicator
 - Standby, blast chill cycle and cancel buttons
 - Diagnostic trouble shooting capability
 - High and low temperature alarm
 - Power and component failure alarms
- Seven (7) day temperature recorder printout on demand
- Front breathing design for zero clearance installation
- Stainless steel, front, sides, door and interior
- Flush mounted doors, anti-condensation heaters and removable magnetic door gaskets



- Twelve (12) adjustable white resin coated wire shelves
- Complies with FDA, NSF 7 and HACCP guidelines
- Heavy duty swivel casters with brakes on front
- No drain required
- Defrost on demand and automatic defrost
- Electro fin, corrosion resistant coils and hyblade fan motors – the engineers choice for the quietest, most powerful and energy efficient fans.
- Precision injected, high density, environment friendly 3" insulation. Provides excellent thermal efficiency with low GWP and zero ODP

Optional Features and Accessories

- HACCP monitoring program
- Factory installed reverse door hinging
- 6" Legs in place of standard casters
- Extra printer paper

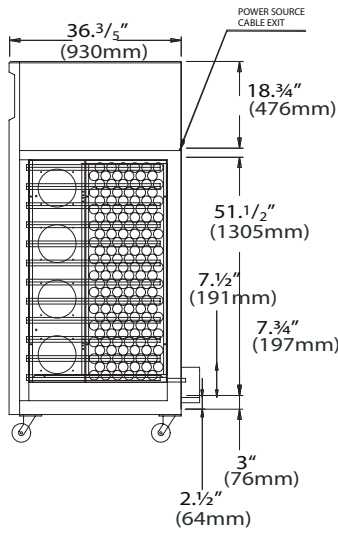

Side View

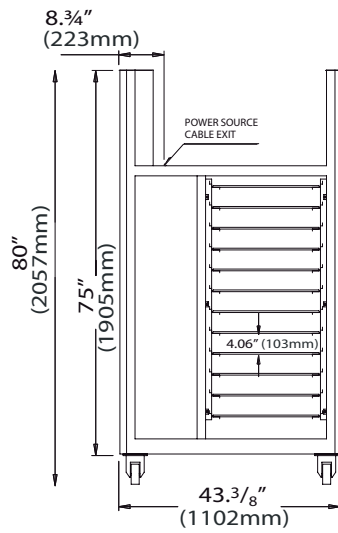

Front View

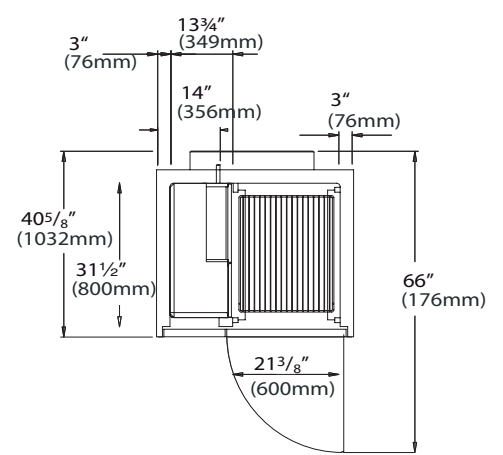

Top View

NOTE: If cabinet is located directly against wall and/or under low ceiling, a minimum clearance of 2" is required.

We reserve the right to change specifications and product design without notice. Such revisions do not entitle the buyer to corresponding changes, improvements, additions or replacements for previously purchased equipment.

Characteristics	WBC110R
Capacity (lbs./90 Mins.)	110
Width, overall	43 ³ / ₈
Depth, overall	40 ⁵ / ₈
Depth, door open 90°	66
Height (incl. castors)	80
Clear door width	21 ³ / ₈
Clear door height	51 ¹ / ₂
No. Of shelves	12 pairs
Cabinet voltage (* not to exceed)	208-230/60/1
Feed wires	2
Total amperes	7.9

Crated dimensions & weights	Height	Width	Depth	Weight (lbs)
WBC-110	86	49 ¹ / ₄	47 ¹ / ₄	559

Refrigeration Data	Refrigerant	Compressor	BTUH*
WBC-110	R-404a		10200

*BTUH @ 90°F. Ambient, +4°F. Evaporator

Dimensional tolerance ± 1/4" Metric dimensions (mm)